





Product Data Sheet

RhinoStop® Standard



Last Updated: September 2025

Crash Test Performance

Vehicle Type	Impact Speed	Impact Height	Impact Energy	Barrier Configuration
 1500 kg	 15 km/h	 0.5m	 12.9 kilojoules	4 m w-beam supported by three (3) posts at 2.0 m centres positioned on the outside edge of a 150 mm elevated concrete slab.

Installation

Anchor Type	Drill Depth	Torque	Anchors per Post	Minimum Concrete Slab Thickness
M20 Fischer FBN II	115 mm	200 Nm	1 off	150 mm

Post Detail

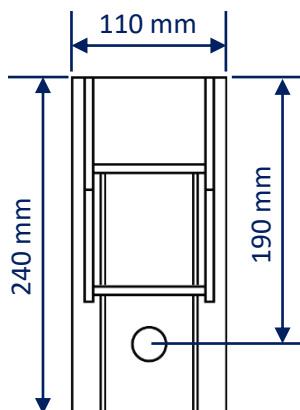
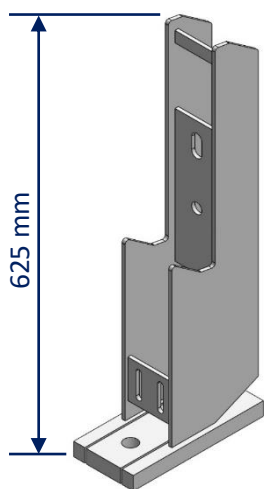

Feature & Benefits

- Crash tested to exceed the 30kN impact condition nominated in AS/NZS 1170.1, Clause 3.8.
- Nil damage to the anchors or 150mm thick elevated slab following crash testing.
- The yielding of the baseplate allows the system to deflect and absorb higher impact loads.
- Fully modular design, can be configured with pedestrian fall protection up to 1300 mm high.
- All steel construction providing long term durability.
- Fewer anchor bolts when compared to traditional rigid post systems.

Product Data Sheet

RhinoStop® Standard

